

M-30.

Unique heat embossing machine with small installation dimensions suitable for label dispensers.
Suitable for label dispensers.

Hot stamping is still the best labelling method for difficult product surfaces and shapes, even if digital and technological developments have produced alternative solutions.

With the development of the M-30, Elmoprint has created a compact and uncomplicated heat-embossing machine which meets the need for printing date, batch number, etc.

A fitting bracket has also been developed for the M-30 and is supplied ready and adapted to each individual make of dispenser.

With an installation dimension of 106 mm, the M-30 can be attached to all dispensers - even where space is at a premium.

In terms of technology and design, the M-30 represents a significant break with the heat-embossing machines used so far. All functions are now built into the machine and together with the fitting bracket, the M-30 is a turn-key solution which can be fitted in a very short time.

The M-30 is the most advanced solution on the market and at the same time the simplest. It is easy to service, clean and dismantle, and another advantage is the low initial cost for both the M-30 and the fitting bracket.

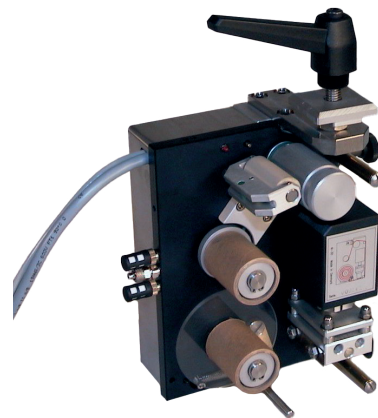

The M-30 hot stamping machine is available in 3 versions:

M-30-0 Standard is suitable for mounting in frames in most labelling applicators and packaging machines, where it can be turned 360°, and moved across the web allowing printing anywhere you require on the packaging film or label.

M-30-5 Cassette is also suitable for mounting in packaging machines and labelling applicators. With a cassette you can quickly shift the hot foil rolls.

M-30-1 with built-in counterpressure plate is easily mounted on a table for manually feeding of subjects to be printed.

All M-30 printers and accessories are made in anodized aluminium and stainless steel.

The standard voltage is 230V, and the printers have built-in solenoid valve and controlboard for setting of printing time and temperature.

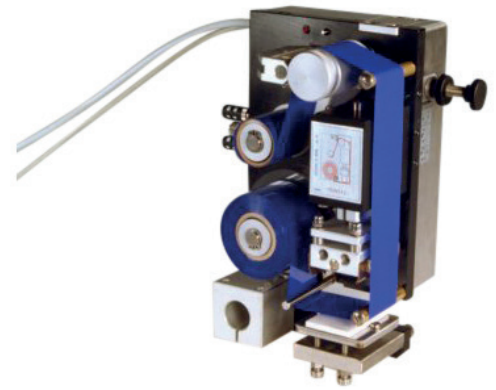
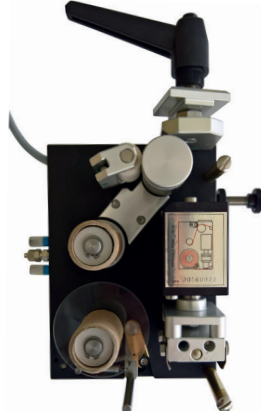
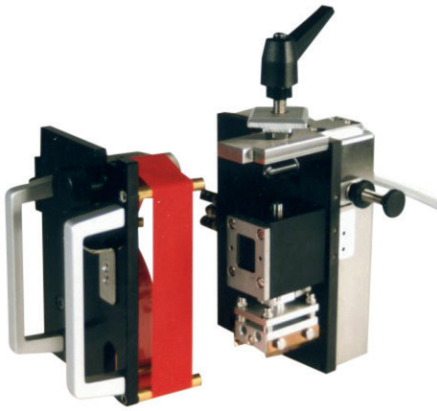

M-30.

Technical specifications.

Operating speed (max. per min.)	150
Max. printing area (mm)	40x20
Working pressure (bar)	2-7
Embossing pressure (N at 6 bar)	500
Air consumption (litres per print)	0,1
Voltage/Wattage	230/75 (115/75)
Dimension LxDxH (mm)	125x100x175 (see drawings)
Weight (kgs)	3,3
Max. length of hot foil (m)	122 (305)
Printing time	adjustable between 0,02 and 1,0 sec.
Printing temperature	adjustable between 80°C and 140°C
Lubrication	filter and reduction valve are fitted at the air inlet. Self-lubricating bronze and teflon bearings
Standard delivery	Ø 6 mm air inlet, 2-metre flex, 230V phase + neutral + earth, 2-metre shielded cable for start signal, 1 retainer plate, 1 "spade" for typeholder.

M-30-0 Standard

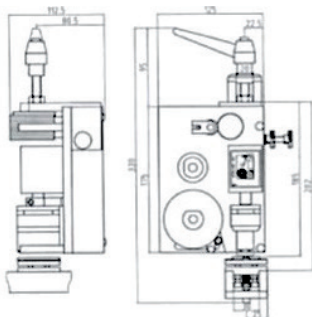

M-30-5 Cassette

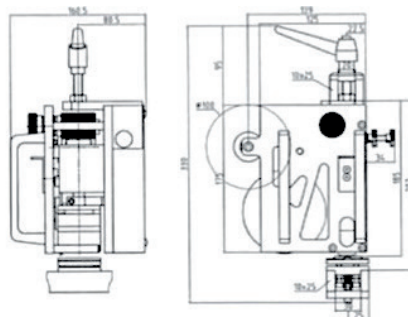

M-30-1 with built-in counter pressure plate

